

# AIR VELOCITY TRANSMITTER

1% and 2% Models, Optional BACnet MS/TP or Modbus®

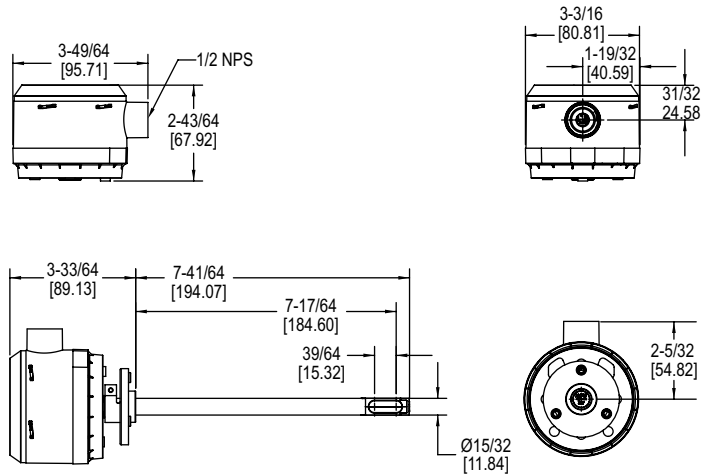

The **Series AVLV Air Velocity Transmitter** quickly and accurately measures air velocity or volumetric flow in imperial or metric units. Simultaneous current and voltage outputs on all models provide universal inputs to monitoring equipment while the output range, units, and 0-5/10 VDC, 4-20 mA output can be configured via local DIP switches. The optional integral display, or the portable remote tool, provide a convenient way to locally monitor process values and configure the unit.

Models are available in 1% and 2% accuracy models and low velocity ranges to suit a variety of needs, and the optional BACnet MS/TP or Modbus® RTU/ASCII communication protocol allows units to be daisy-chained while providing access to all of the velocity and flow data, as well as additional information such as air temperature. The lower ranges in these high accuracy units allow for applications in quality intensive environments, such as the pharmaceutical industry.

**BENEFITS/FEATURES**

- Minimal preventative maintenance as sensing element is covered with an engineered protective coating
- Easy field setup via the on board dip switches for range and units

**APPLICATIONS**

- VAV systems
- Building ducts
- Clean room systems

MODEL CHART		
Model	Accuracy	Output
AVLV-1DA1	±1%	Universal current/voltage outputs
AVLV-1DB1	±1%	BACnet communication
AVLV-1DM1	±1%	Modbus® communication
AVLV-2DA1	±2%	Universal current/voltage outputs
AVLV-2DB1	±2%	BACnet communication
AVLV-2DM1	±2%	Modbus® communication

OPTIONS	
To order add suffix:	Description
-FC	Factory calibration certificate
-GLD	Electrical cable gland
-LCD	LCD display
-NIST	NIST certificate

Example: AVLV-1DA1-LCD

**SPECIFICATIONS**

**Service:** Clean air and non-combustible, compatible gases.  
**Wetted Materials:** Consult factory.  
**Range:** 100, 200, 300, 400 FPM (0.5, 1, 1.5, 2 m/s); field selectable.  
**Accuracy:** See chart.  
**Temperature Limits:** 32 to 122°F (0 to 50°C).  
**Power Requirements:** 24 VDC ±20% or 24 VAC ±20%.  
**Humidity Limits:** 5 to 95% RH, non-condensing.  
**Output Signals:** 4-20 mA, 0-5 VDC, 0-10 VDC.  
**Response Time (90%):** 4 s, typical; 1 s at constant temperature.  
**Zero and Span Adjustments:** Digital push buttons.  
**Output Load Resistance:** Current output: 0 to 1100 Ω max.; Voltage output: Minimum load resistance 1 kΩ.  
**Current Consumption:** 60 mA max.  
**Display:** 5 digit LCD (optional).  
**Electrical Connections:** Analog: Power and output: 4-wire removable European style terminal block for 16 to 26 AWG; Communication: Connections: BACnet MS/TP or Modbus® RTU/ASCII: 3-wire removable European style terminal block for 16 to 26 AWG.  
**Supported Communication Baud Rates:** 9600, 19200, 38400, 57600, 76800, 115200 (optional).  
**Device Load:** 1/8 unit load.  
**Electrical Entry:** 1/2" NPS thread; Accessory: Cable gland for 5 to 10 mm diameter cable, A-151.  
**Enclosure Rating:** NEMA 4X (IP66).  
**Mounting Orientation:** Flow direction must be parallel to the sensor tip.  
**Weight:** 6.0 oz (160 g).  
**Compliance:** BTL, CE.

**ACCURACY CHART**

Velocity Range	Accuracy Rating*
20 to 100 FPM (0.15 to 0.5 m/s)	± (2% of reading + 0.04 m/s [7.9 FPM]) ± (1% of reading + 0.04 m/s [7.9 FPM])
20 to 200 FPM (0.15 to 1.0 m/s)	± (2% of reading + 0.04 m/s [7.9 FPM]) ± (1% of reading + 0.04 m/s [7.9 FPM])
20 to 300 FPM (0.15 to 1.5 m/s)	± (2% of reading + 0.05 m/s [9.8 FPM]) ± (1% of reading + 0.05 m/s [9.8 FPM])
20 to 400 FPM (0.15 to 2.0 m/s)	± (2% of reading + 0.06 m/s [11.8 FPM]) ± (1% of reading + 0.06 m/s [11.8 FPM])

\*Accuracy dependent on model selected when ordering.

Modbus® is a registered trademark of Schneider Electric USA, Inc.